



WHALLON
MACHINERY, INC.

MATERIAL HANDLING
EQUIPMENT

WHALLON MACHINERY, INC.

205 N. Chicago Street • P.O. Box 429

Royal Center, IN 46978

Ph: 574-643-9561 • Fax: 574-643-9218

www.whallon.com



PH SERIES

Pallet Stacking/Dispensing



WHALLON
MACHINERY, INC.

MATERIAL HANDLING
EQUIPMENT

WHALLON MACHINERY, INC.

205 N. Chicago Street • P.O. Box 429

Royal Center, IN 46978

Ph: 574-643-9561 • Fax: 574-643-9218

www.whallon.com

Pallet Stacking/Dispensing

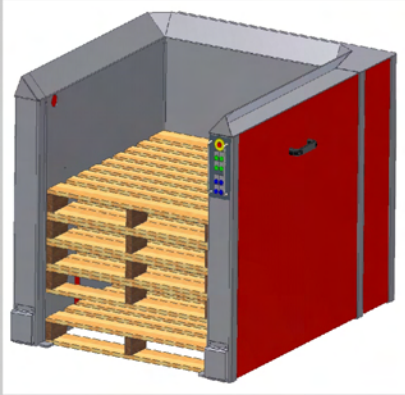

Pallets are Stacked from and/or Dispensed to the Floor

PH-100

- Economical and energy efficient - 110V
- No air required
- Reduce operator injury by eliminating manual handling of pallets
- Load and unload pallets by using pallet jack
- Compatible with WHALLON pallet conveyors
- Pallet stacks up to 100" can be automatically conveyed into bin or discharged from bin when used with WHALLON pallet conveyor
- Can be manufactured to handle any size pallet
- Built from heavy duty 7 gauge steel with 1/4" wall tubular posts
- Controlled by Allen Bradley MicroLogix 1000

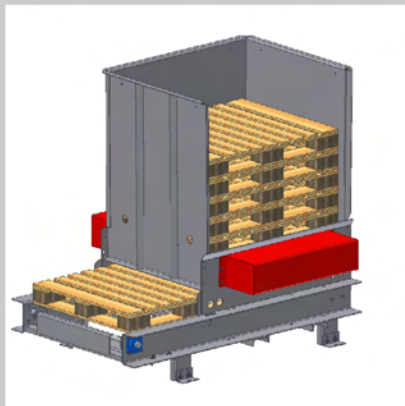

Pallets are Stacked from and/or Dispensed to a Conveyor Line

PH-200

- Wired for 220/460, 3 phase, 24VDC control voltage
- Less than 1 SCFM air @ 40PSI
- Pallets can be dispensed or stacked from 1 or 2 conveyor lines
- Pallet storage bin can hold up to 10 to 12 pallets
- Storage bin extensions can be added for additional pallet storage
- Chain conveyor can be made any length, width, or height to match new or existing line
- Can be manufactured to handle any size pallet
- Extra rugged construction built from 1/4" plate to help withstand forklift damage
- Controlled by Allen Bradley MicroLogix 1100E or can be added to existing equipment PLC in certain applications



Multiple Sized Pallets are Stacked from and/or Dispensed to a Conveyor Line

PH-250

- Adjustable side panels to handle multiple pallet widths from 40" to 96"
- Can be built with 1 or 2 adjustable side panels
- Both manual or automatic panel adjustment available
- Wired for 220/460, 3 phase, 24VDC control voltage
- 2 SCFM air @ 60PSI
- Pallet storage bin can hold up to 10 to 12 pallets
- Storage bin extensions can be added for additional pallet storage
- Extra rugged construction built from 1/4" plate to help withstand forklift damage
- Controlled by Allen Bradley MicroLogix 1100E or can be added to existing equipment PLC in certain applications