

# Pallet Stackers/Dispensers

Whallon produces a variety of equipment to help you move and manage your empty pallets with maximum efficiency. Like all Whallon products, our empty pallet handling equipment is based on more than 35 years of service to the material handling industry. You get affordable, reliable machinery built from heavy-duty components and proven controls. It all adds up to years of trouble-free service at some of the lowest prices around. That's why it pays to ask for Whallon.

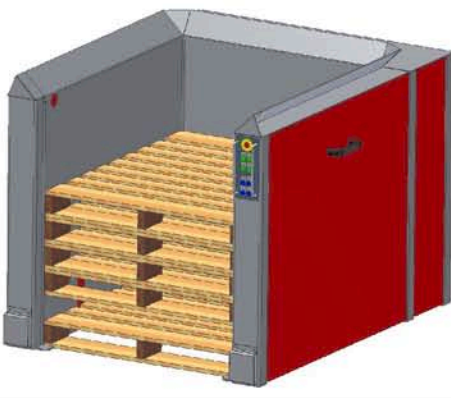

# Pallet Stackers/Dispensers



## Pallets are Stacked from and/or Dispensed to the Floor

**PH-100**

- Economical and energy efficient - 110V or 3 Phase
- No air required
- Reduce operator injury by eliminating manual handling of pallets
- Load and unload pallets by using pallet jack
- Compatible with WHALLON pallet conveyors
- Pallet stacks up to 100" can be automatically conveyed into bin or discharged from bin when used with WHALLON pallet conveyor
- Can be manufactured to handle any size pallet
- Built from heavy duty 7 gauge steel with 1/4" wall tubular posts
- Controlled by Allen Bradley MicroLogix 1000

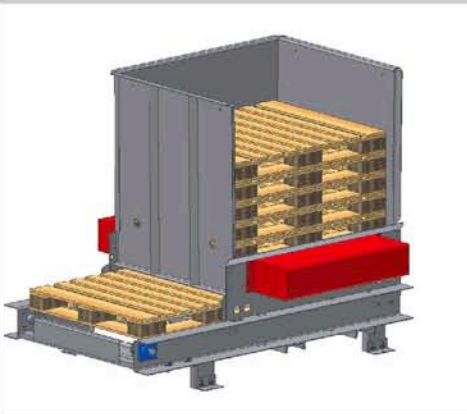

## Pallets are Stacked from and/or Dispensed to a Conveyor Line

**PH-200**

- Wired for 220/460, 3 phase, 24VDC control voltage
- Less than 1 SCFM air @ 40PSI
- Pallets can be dispensed or stacked from 1 or 2 conveyor lines
- Pallet storage bin can hold up to 10 to 12 pallets
- Storage bin extensions can be added for additional pallet storage
- Chain conveyor can be made any length, width, or height to match new or existing line
- Can be manufactured to handle any size pallet
- Extra rugged construction built from 1/4" plate to help withstand forklift damage
- Controlled by Allen Bradley MicroLogix 1100E or can be added to existing equipment PLC in certain applications

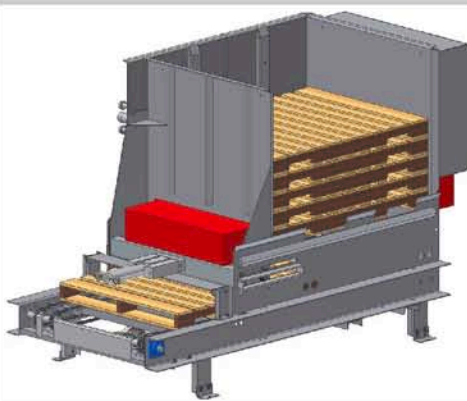

## Multiple Sized Pallets are Stacked from and/or Dispensed to a Conveyor Line

**PH-250**

- Adjustable side panels to handle multiple pallet widths from 40" to 96"
- Can be built with 1 or 2 adjustable side panels
- Both manual or automatic panel adjustment available
- Wired for 220/460, 3 phase, 24VDC control voltage
- 2 SCFM air @ 60PSI
- Pallet storage bin can hold up to 10 to 12 pallets
- Storage bin extensions can be added for additional pallet storage
- Extra rugged construction built from 1/4" plate to help withstand forklift damage
- Controlled by Allen Bradley MicroLogix 1100E or can be added to existing equipment PLC in certain applications